

Cl. I, Div. 1 & 2, Groups A, B, C, D† Explosionproof
 Cl. II, Div. 1, Groups E, F, G Dust-Ignitionproof
 Cl. II, Div. 2, Groups F, G
 Cl. III

Applications:

- UNY and UNF unions are installed in threaded thickwall conduit systems:
- UNY – to connect conduit to a conduit fitting, junction box or device enclosure
 - UNF – to connect conduit to conduit, or to provide a means for future modification of the conduit system

UNA unions are used in conduit and fitting installations when entrance angle is between 90° and 180°.

EL elbows are installed in conduit run or in box or fitting hub:

- To change direction in threaded rigid conduit run by 90°, or when terminating at a box or fitting

Features:

UNY, UNF and UNL unions have:

- Compact design which permits assembly with a minimum of clearance to other adjacent conduit and/or equipment
- Strong and durable construction

UNA unions:

- Have a single clamping nut on angle, making it both a union and a connector
- Permit conduit joints at angles between 90° and 180°

EL elbows have a smooth interior and are both strong and compact.

Certifications and Complies:

- NEC/CEC:

Class I, Division 1 & 2, Groups A, B, C, D
Class II, Division 1, Groups E, F, G
Class II, Division 2, Groups F, G
Class III
EL 1/2", 3/4", 1"
UNF/UNY 105, -215, -205, -305
UNL 105, -125, -215, -205

Class I, Division 1 & 2, Groups B, C, D
Class II, Division 1, Groups E, F, G
Class II, Division 2, Groups F, G
Class III
UNF/UNY 406, -506, -606, -706, -806, -905, -1005

Class I, Division 1 & 2, Groups C, D
Class II, Division 1, Groups E, F, G
Class II, Division 2, Groups F, G
Class III
EL, UNF, UNL, UNY - all sizes

Class I, Division 1 & 2, Group D
Class II, Division 1, Groups E, F, G
Class II, Division 2, Groups F, G
Class III
UNA

- UL Standard: 1203
- CSA Standard: C22.2 No. 30

†See compliances for classification of each product.

Standard Materials:

- UNY, UNF unions – 1/2" to 1" – steel
- UNY, UNF unions – 1 1/4" to 6" – *Feraloy*® iron alloy
- UNL, UNA unions – *Feraloy* iron alloy
- EL elbows – *Feraloy* iron alloy or ductile iron

Standard Finishes:

- Steel – electrogalvanized with chromate treatment
- *Feraloy* iron alloy, malleable iron – electrogalvanized and aluminum acrylic paint

Options:

Description
 Copper-free aluminum
 Not available on UNA or 5" and 6" UNY/UNF

Suffix
 SA

UNY

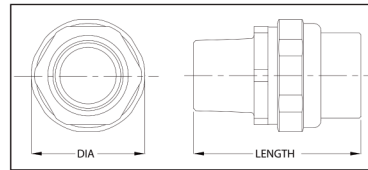

UNL



90° Angle

Size	Cat. #
1/2 to 1/2	UNL105
3/4 female to 1/2 male	UNL125
1/2 female to 3/4 male	UNL215
3/4 to 3/4	UNL205

Dimensions In Inches:

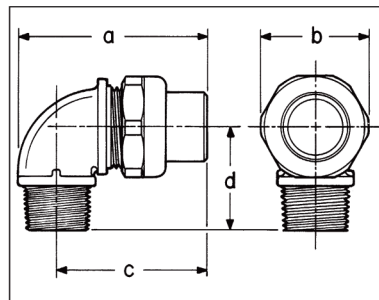

UNY Male



1/2" – 4"



5" – 6"

UNF Female



1/2" – 4"



5" – 6"

Size	Cat. #	Size	Cat. #
1/2	UNY105	1/2	UNF105
1/2 female to 3/4 male	UNY215	3/4 to 1/2	UNF215
3/4	UNY205	3/4	UNF205
1	UNY305	1	UNF305
1 1/4	UNY405	1 1/4	UNF405
1 1/4	UNY406	1 1/4	UNF406
1 1/2	UNY505	1 1/2	UNF505
1 1/2	UNY506	1 1/2	UNF506
2	UNY605	2	UNF605
2	UNY606	2	UNF606
2 1/2	UNY705	2 1/2	UNF705
2 1/2	UNY706	2 1/2	UNF706
3	UNY805	3	UNF805
3	UNY806	3	UNF806
3 1/2	UNY905	3 1/2	UNF905
4	UNY1005	4	UNF1005
5	UNY012	5	UNF012
6	UNY014	6	UNF014

Size	UNY		UNF	
	Length	Max. Dia.	Length	Max. Dia.
1/2	2 5/8	1 1/2	1 13/16	1 1/2
3/4 – 1/2	2 11/16	1 13/16	1 3/4	1 13/16
3/4	2 11/16	1 13/16	1 3/4	1 13/16
1	3	1 7/8	2	1 7/8
1 1/4	3 11/16	2 1/4	2 1/4	2 3/4
1 1/2	4 1/4	3 1/8	2 5/8	3 1/8
2	4 1/4	3 13/16	2 9/16	3 13/16
2 1/2	5 1/8	4 3/8	3 3/8	4 3/8
3	5 3/4	5 1/8	3 7/8	5 1/8
3 1/2	6 1/2	5 11/16	4 1/8	5 11/16
4	6 5/8	6 1/8	4 1/8	6 3/8
5	6 1/8	8 7/16	3 13/16	8 7/16
6	6 1/8	9 7/16	3 13/16	9 7/16

Dim.	105	125	215	205
a	2 11/16	2 11/16	2 7/8	2 7/8
b	1 17/32	1 13/16	1 13/16	1 13/16
c	2 1/8	2 1/8	2 1/4	2 1/4
d	1 7/16	1 7/16	1 5/8	1 5/8